

DOSING PUMP for DETERGENTS and WAXES

www.recambiospresion.com



Please read the operating instructions manual through completely before commissioning this equipment
Do not discard, the operator shall be liable for any damage caused by installation or operating errors

1	Unpacking	(1)
2	Install	(2)
3	Introduce	(5)
4	Capacity	(8)
5	Components&Functions	(9)
6	Flow adjusting and Key setting	(10)
7	Repairs	(14)
8	Assembly	(15)

1 Unpacking

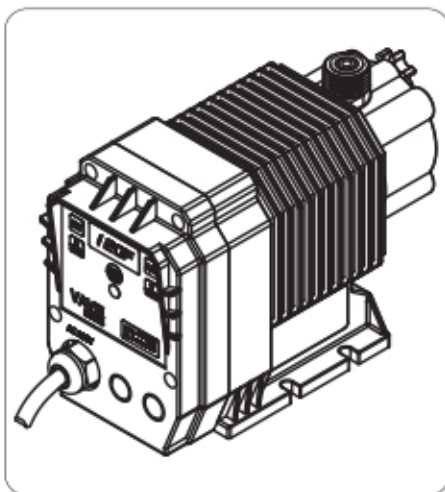

Packing list

Number	Name	Quantity	Material
A0011552*	Anti-syphon valve	1	Polypropylene
A001256	Injection valve	1	Polypropylene
A001257	Foot valve	1	Polypropylene
A001158	Discharge tubing	1	3. 2m/Polyethylene
A001159	Suction tubing	1	1. 6m/Polyvinyl chloride
A001160**	Back tubing	1	0.8m/Polyvinyl chloride
A001261	Connection	2	2Nut&2Clasp&2Nozzle
A001162	O-ring	2	Spare/EPDM

* A0011552 may not be included in the packing list , Please contact the dealer to buy if you need it;

** A001160 just for the type of exhaust function;

2 Install

2.1.1 Typical Installation

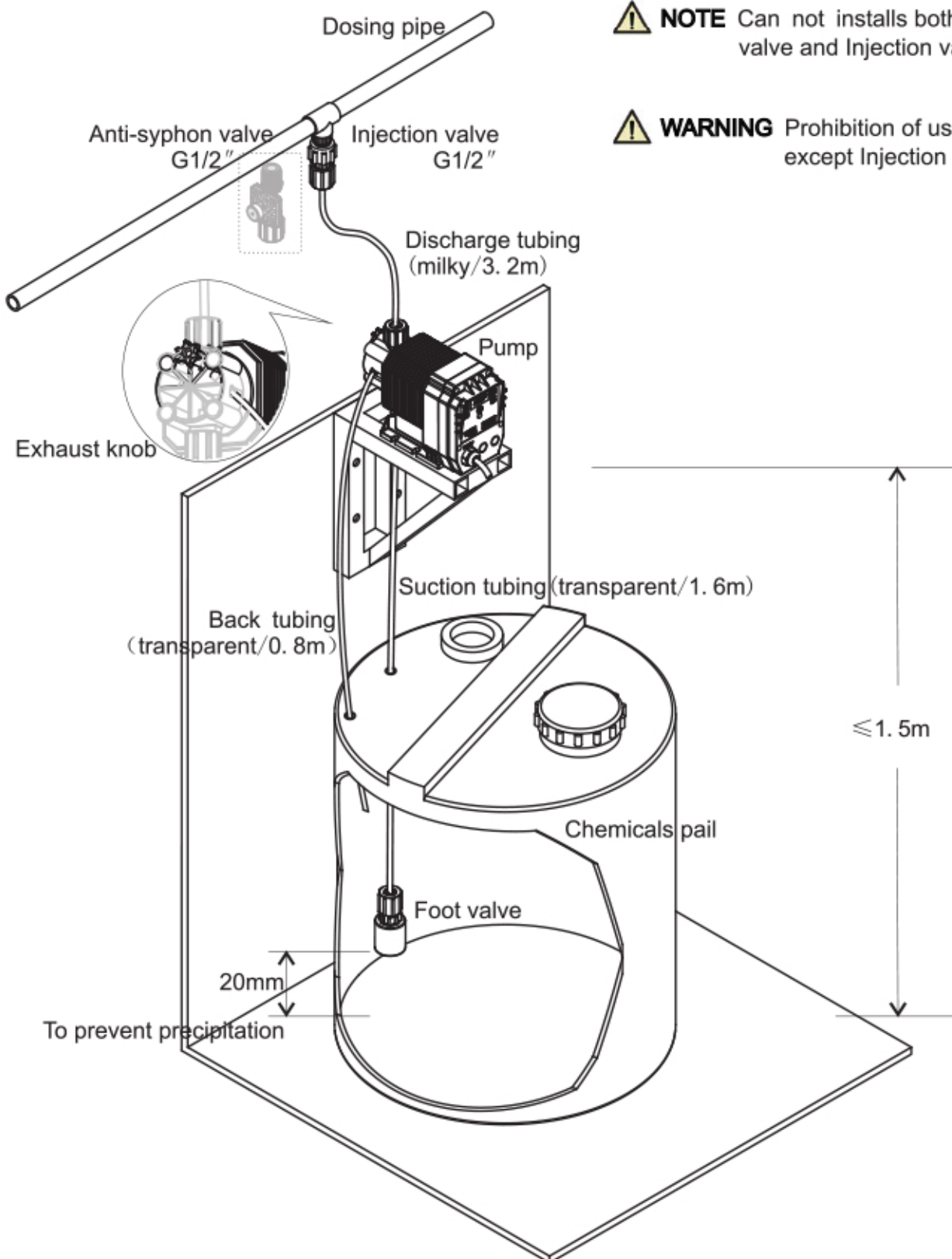

NOTE Can not install both Anti-syphon valve and Injection valve

WARNING Prohibition of use teflon tape except Injection valve

2. 1. 2 Other installation(Simple)

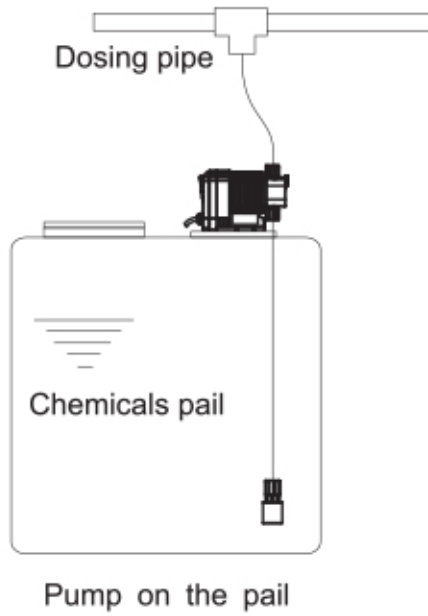

2. 1. 3 Other installation(Perfusion)

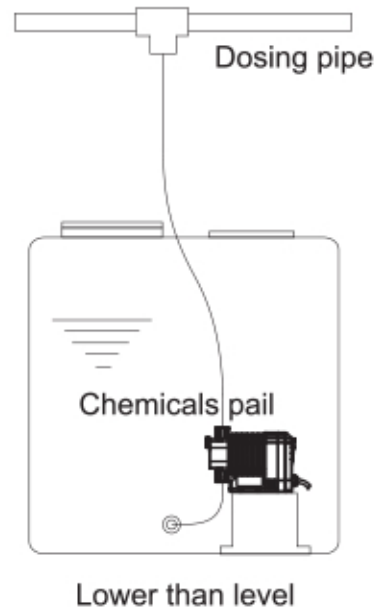

2. 1. 4 Other installation(Syphon)

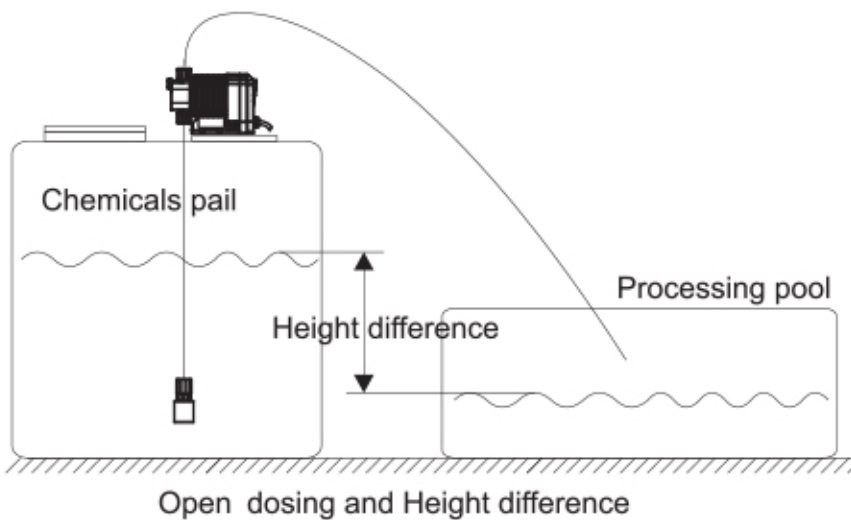

2. 1. 5 Other installation(Syphon)

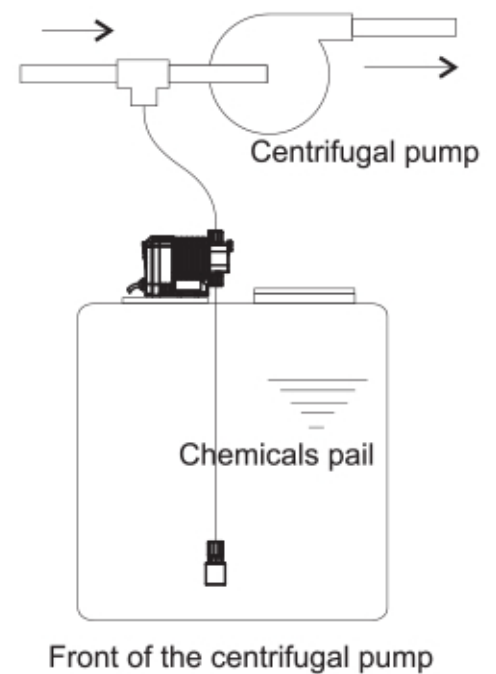

 **NOTE** 2. 1. 4 and 2. 1. 5 may be syphon, it need an anti-syphon valve

2.2 Back tubing installation

- One end of back tubing inserted into the head, the other end put into the Chemicals pail

⚠ WARNING Ensure the back tubing be tight, otherwise the chemicals can be splashed

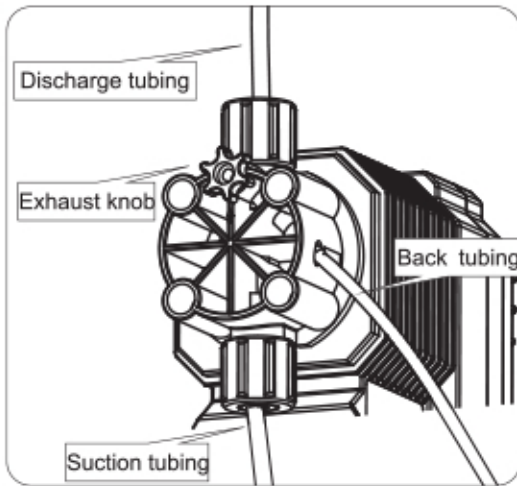

2.3 Connection installation

- Put the nut and clasp over the tubing
- Put the tubing into the nozzle hard

⚠ WARNING Discharge tubing can not be folded

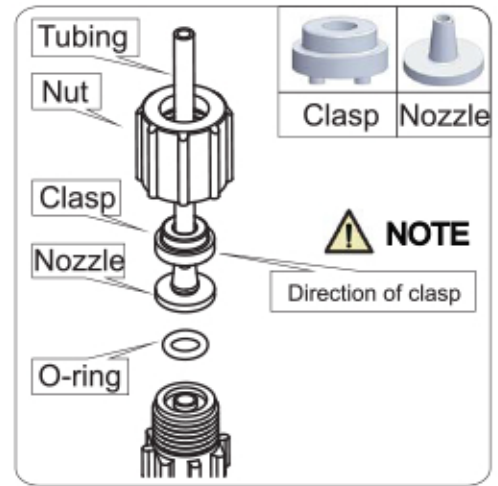

2.4 Foot valve installation



2.5 Injection valve installation

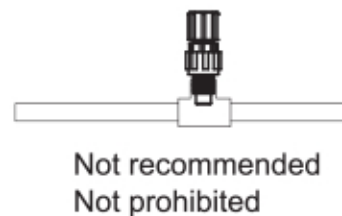

3 Introduce

3.1 Summary

The dosing pump is controlled by a microprocessor, a fixed stroke length, variable stroke frequency, diaphragm driven by electromagnets, can be used to transport a variety of chemicals dosing.

3.2 Principle

The electromagnetic force to drive the diaphragm motion in the pump head, the pressure variations caused by suction valve and discharge valve automatically open and close realization of chemical dosing.

The pump in 0.48~15.20 L/h range, the maximum output pressure of 8.2~1.8 bar can adjust the flow according to the regulation of frequency.

3.3 Parameters

Repeated accuracy	-3%~+3%
Ambient temperature	5~42°C (indoor or outdoor in shade)
Chemicals temperature	5~45°C (polypropylene head)
Chemicals viscosity	≤300mPa · s
Particle diameter	≤0.15mm
Voltage	AC 220V 50/60Hz -10%~+15% AC 110V 50/60Hz -10%~+15%

Series	Power
F series	9W\12W
V series	12W\16W\24W\30W
C series	35W\40W\49W

Protection grade	IP55
Insulation grade	F
Explosion-proof grade	None
External pulse signal	Passive signal Frequency≤40K/min
External analog signal	0/4~20mA or 0~5V

3.4 Explanation of Model

V	T	05006	PP	1	A	6	0	0	0		
							Accessory		0:Standard 1:Fully* 2:Optional		
							Voltage		0:AC 220V 50/60Hz 1:AC 110V 50/60Hz		
							Valve spring**		0:NONE 1:YES		
							Tubing		6: 4*6mm 9: 7*10mm		
							Relay		A:None C:Diaphragm broken***	B:Level D:B+C	
							Seal		1:EPDM 3:NBR	2:FKM 4:PTFE	
							Pump head		PP:polypropylene FF:PTFE	PV:polyvinyl chloride PF:PVDF PS:Stainless	
							Capability*		Flow:top three Pressure:last two		
							Control		D: Manual T: Cycle timer	P: Pulse signal t: 7 days timer	A: Analog signal S: RS485
Series							V series		F series	C series	

* Standard: 1 Injection valve, 1 foot valve, 2 Connections, 3 Tubings, 2 O-rings
Fully: Standard+Anti-syphon valve

** Spring valve used for high viscosity chemicals

***Series V&F have no this option

3.5 Dimension

V series

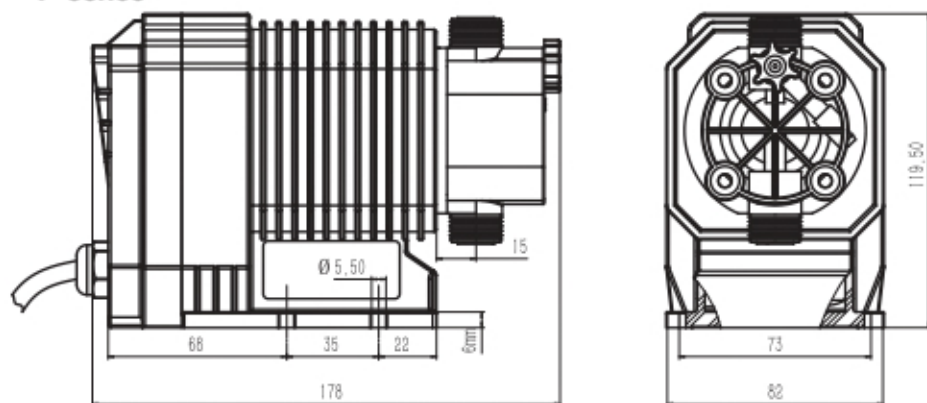

4 Capability

V series

Model	Flow L/h	Pressure Bar	Frequency N/min	Model	Flow L/h	Pressure Bar	Frequency N/min
00508	0.48	8.2	90	06005	6.00	4.8	160
01008	1.08	8.2	90	08004	8.16	3.8	160
02008	2.16	8.2	120	09003	9.00	3.5	160
03008	3.12	7.6	120	10004	10.20	3.2	160
04006	3.60	6.8	120	12003	12.48	2.8	180
05006	5.04	6.2	160	15002	15.20	1.8	180

5 Components&Functions

5.2 V series

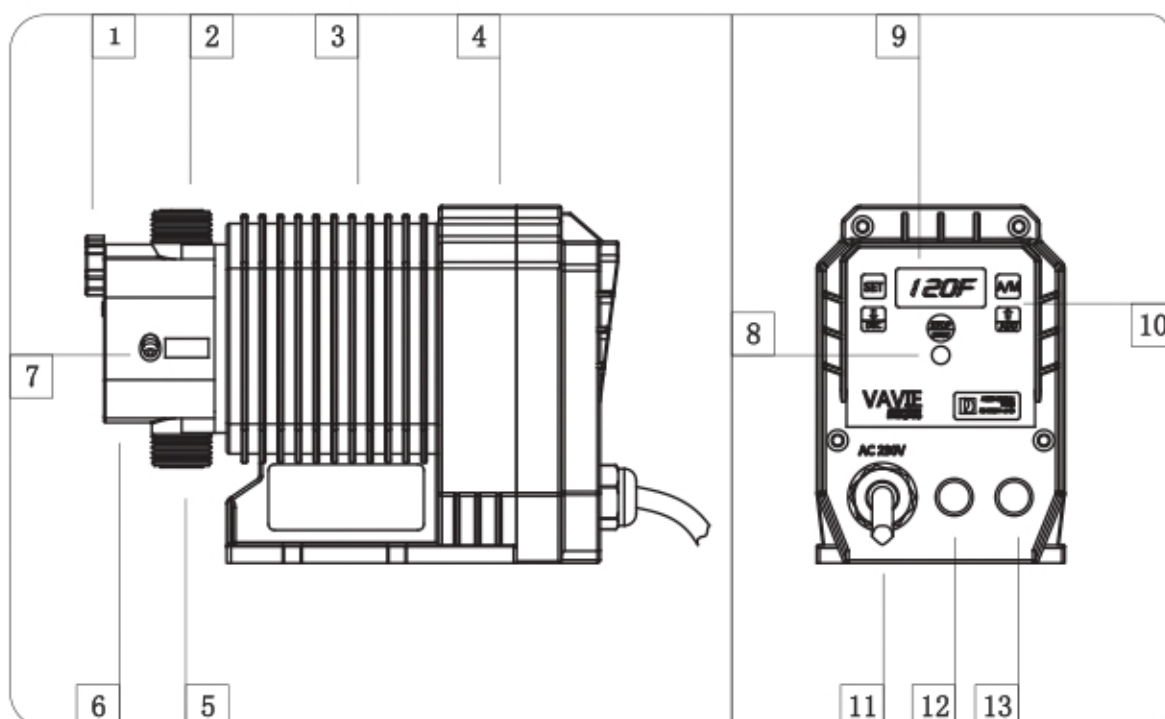

- | | | |
|--------------------|----------------------|----------------------|
| 1、 Exhaust knob | 5、 Suction valve | 9、 Frequency display |
| 2、 Discharge valve | 6、 Pump head | 10、 Keys |
| 3、 Back cover | 7、 Back tubing jack | 11、 AC 220V |
| 4、 Front cover | 8、 Runing indication | 12、 Level |
| | | 13、 Control signal |

6 Flow adjusting and Key setting

6.1 Accessory function

- Anti-syphon valve: connecting tubing and dosing pipe, anti-syphon ;
- Injection valve: connecting tubing and dosing pipe, check and a little anti-syphon ;
- Foot valve: filtration and check.

6.2 Power

- Please ensure the external voltage and the pump consistent
In case of inductive load and dosing pump parallel access power supply
The switch contacts need to use, for example, a relay or contactor.
- For the external control signal, Green is connected with the anode,
yellow is the negative pole

6.3 Start the dosing pump

- Unscrew the exhaust knob about a circle
- Start the pump, until you can see the chemicals appears at the back tubing
- Tightened the exhaust knob



NOTE If the pump head have no exhaust knob,
you can unscrew the nut on the discharge valve to exhaust

6.4 Key setting

6.4.1 F series

- Adjusting the frequency by the knob
- Rotating the knob counterclockwise, until hear "click", the dosing pump will stop

6.4.2 V series

6.4.2.1 VT type(manual)

- **XXXXF** (XXX is frequency, for example **120F** unit: N/min)
- Press **STOP** stop or start pump, stop display **OFF** start display **XXXXF**
- Press **▲** or **▼** adjusting the frequency
- The frequency of LED flickering is same as the frequency of pump

Circle timer setting (unit: minute)

- Press **A.M** to switching control mode, **XXXXF** means manual, **XXXXR** means circle time
- **XXXXR** Press **SET** the first time, display **1.255** this 255 is running time
- Press **▲** or **▼** adjust the 255
- Press **SET** the second time, display **2.255** this 255 is stop time
- Press **▲** or **▼** adjust the 255
- Press **SET** third time, save settings, display **XXXXR**

For example, setting as **1. 5** **2. 49** it means running 5 minutes, stop 49 minutes



NOTE This function of VT type is controlled by the timer in MCU of pump, the accuracy is a little poor about 15 seconds per hour, the C series Ct type can provide high accuracy cause it is controlled by off-chip clock MCU.

6.4.2.2 VP type(Pulse signal)

The setting of manual is the same as VT type.

Setting of auto:

- Press **A.M** to switching control mode, **XXXXF** means manual, **XXXXP** means auto
- Press **▲** or **▼** adjust the frequency
- **XXXXP** Press **SET** the first time, display **1. 1** or **1. 0**

1. 0 means 1/N, **1. 1** means N/1)

1/N means one external signal, pump run N times

N/1 means N external signal, pump run one times

- Press **▲** or **▼** to switching 1/N or N/1
- Press **SET** the second time, display **2. 1** (it means the N)
- Press **▲** or **▼** adjust it
- Press **SET** third time, save settings, display **XXXXP**
- Press **STOP** stop or start pump

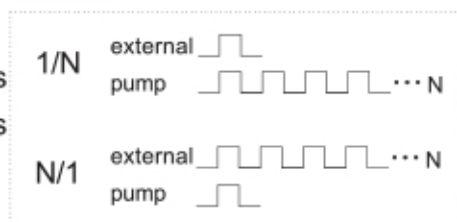

6.4.2.3 VA type (analog signal)

The setting of manual is the same as VT type.

Setting of auto:

- Press **A/M** to switching control mode, **XXXXF** means manual, **XXXXR** means auto
- **XXXXR** Press **SET** the first time, display **1. 4.0** it means min. current
- Press **↑** or **↓** adjust it
- Press **SET** the second time, display **2. 20.0** it means max. current
- Press **↑** or **↓** adjust it
- Press **SET** the third time, display **3. 0** it means min. frequency
- Press **↑** or **↓** adjust it
- Press **SET** the fourth time, display **4. XXX** it means max. frequency
- Press **↑** or **↓** adjust it
- Press **SET** the fifth time, save settings, display **XXXXR**
- Press **STOP** stop or start pump

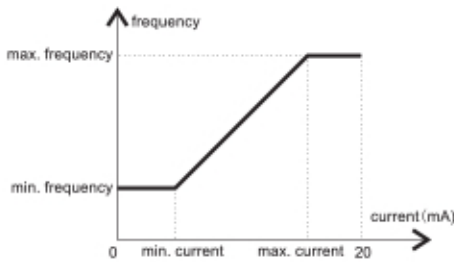

Direct proportion

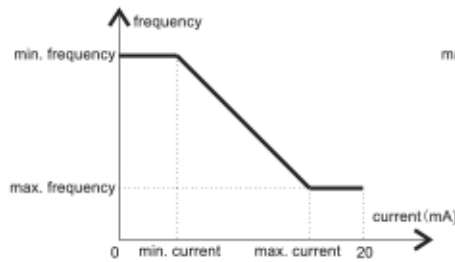

Inverse proportion

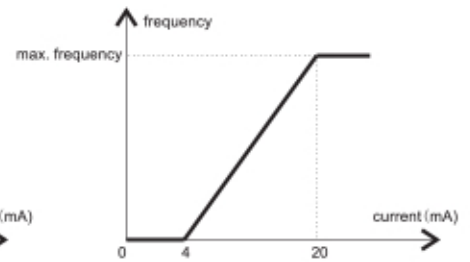

Original settings

6.4.3 C series CT type (circle timer)

Setting of manual

- Press **STOP** stop or start pump, display Stop or Run
- Press **↑** or **↓** adjust the frequency

Setting of circle timer

- Press **A/M** to switching control mode, Manu or Auto
- Press **SET** the first time, display **>XXX** it means running time
- Press **↑** or **↓** adjust it
- Press **SET** the second time, display **<XXX** it means stop time
- Press **↑** or **↓** adjust it
- Press **SET** third time, save settings

Manu	N/m
Run	160

Auto	
Run	160

Auto	>XXX
Run	160

Auto	<XXX
Run	160

Ct type, CA type, CP type and CS type please Refer to the appendix

6.5 Flow regulating and calibration



6.5.1 V series, C series

Flow regulating is achieved by adjusting the frequency
The formula like this:

$$\text{Setting frequency} = \text{max. frequency} * \frac{\text{needed flow}}{\text{max. flow}}$$

"max. frequency" and "max. flow" can be found in the capability table
For example 03008:
the max. flow is 3.12L/h@7.6Bar
the max. frequency is 120N/min
if the needed flow is 2.00L/h, so:

$$\text{Setting frequency} = 120 * \frac{2.00}{3.12} \quad \text{The setting frequency is 76.9}$$

Press  or  adjust the frequency to 77

6.5.2 F series

Flow regulating is achieved by adjusting the knob
The formula like this:

$$\text{needed flow} = \text{max. flow} * \text{percentage of index plate}$$

6.5.3 Flow calibration

If the pressure of dosing pipe is different with the pump max. pressure, the "max. flow" in 6.5.1 would changed, calibration like this:

- Correct installation until normal dosing
- Adjust the frequency to max, and measure the flow by stopwatch
- This flow is real "max. flow"

 **NOTE** You need take the foot valve out of the graduate when calibration finished
Then the air maybe into the tubing, so it is necessary to exhaust again.

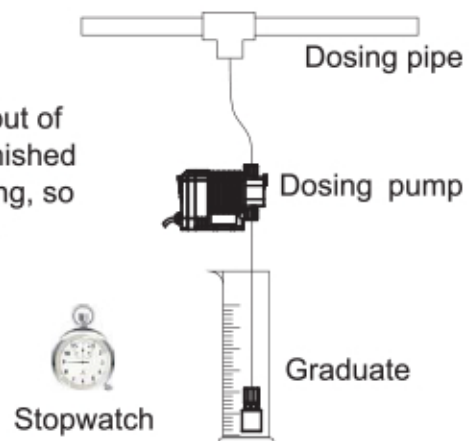

7 Repairs

 **NOTE** The size of the fonts has nothing to do with importance

	Fault phenomenon	Fault cause and solution
Start-up	Can not start	Check the power or press 
	Completely unable to suction	The suction assembly is leak hard
	Suction just a little chemicals	The suction assembly is leak lightly
		Unscrew the exhaust knob about a circle
		Perfusion a little water into the discharge valve
	The vertical distance between pump and chemicals pail is too far	
First running	Discharge valve leak	Check the connection of discharge valve
	Flow too small	Bubbles appear in discharge tubing cause suction assembly is leak lightly
		The pressure of dosing pipe is too high or the discharge tubing is too long
		Incorrectly install the suction tubing on the side of discharge
	The density or viscosity of chemicals is too high	
Flow is too large	The frequency is too high	
	Install installation like the 2.1.4 or 2.1.5, the chemicals still flow when the pump is stoped, it need an anti-syphon valve	
Long running	Discharge valve leak	Check whether the discharge assembly is broken
	Completely unable to suction	Check whether the suction assembly is broken
		The blocking is caused by chemicals crystalline or solidification when pump stop
	Flow too small	The complete blocking is caused by chemicals impurities
		The lightly blocking is caused by chemicals crystalline or solidification when pump running
	Flow is too large	The low power is caused by motor aging
The spring in injection valve is corroded, the anti-syphon is invalid		
Fault	Noise	Poor lubrication of motor
	LED flickering but pump no running	The motor is broken
	Display but LED no flickering	Circuit board is broken
	No display and LED no flickering	Circuit board is broken
Electrical parameters	Fuse	3T 2A/250V
	Power -line terminal	$\approx 1K \Omega$ (Power cut-out)
	Motor	272~285 Ω (Power cut-out)

8 Assembly

Diaphragm

